



### Application

Triple-eccentric butterfly valves are industrial valves, which designed to fully open or close the passage of the working medium flowing through a pipeline. They can also be used for flow-control purposes. However, the tightness of the valve cannot be guaranteed in a long-term use for control purposes.

### Working medium

- waste and service water
- drinking water
- hot water
- steam
- non-aggressive liquids and gases (natural gas, co-gas, petroleum products, etc.).

### Maximum working temperature

A maximum working temperature of the butterfly valve is +400 °C, by agreement up to +550 °C and depends on the body material used.

### Technical description

#### Triple eccentricity - Fig. A

1. the operating shaft axis is eccentric to the packing axis
2. the operating shaft axis is eccentric to the axis of the flow
3. the axis of the seat cone is eccentric to the axis of the flow

Triple eccentricity assures, that the packing stays out of sealing surface of the body except for the closed position, which results in long life-time of the packing (sealing) and lots of cycles. The triple eccentricity design immediately divides the disc from the sealing surface and when closing the valve the disc touches sealing surface just before closure. By this is the closing and opening torque lower and the opening and closing of the valve is done by very little friction. This makes the valves life-time longer. Butterfly valve is both-side tight. The arrow stamped on the valve body corresponds with the direction of the long-term tightness.

Stems of the butterfly valves manufactured according to TA-Luft standard or in compliance with Fugitive Emission are tightened through the Quick set seal from Garlock company.

The butterfly valves are produced of wrought or cast material. Seal material is metal x metal or metal x graphite seal ring.

### Operation

- manual gear-box
- electric actuator
- pneumatic or hydraulic actuator
- remote control from stand

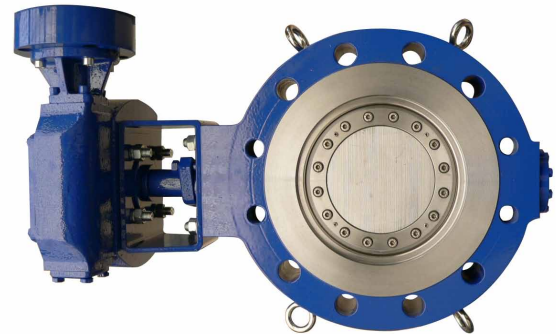

### Testing

The valves are tested according to

- EN 12 266-1
- EN 12 266-2
- EN 13 3060-2.

### Connection to piping

- **wafer type** acc. to EN 1092-1, face to face dimensions acc. to EN 558-1, Series 16, 20, 25
  - **flanged ends** acc. to EN 1092-1, face to face dimensions acc. to EN 558-1, Series 13, 14, 16
  - **welded ends** acc. to ČSN 13 1075, EN 12 627, face to face dimensions acc. to EN 558-1, Series 14
- Other face to face and connecting dimensions are acc. to the customer's requirement, e.g. GOST, ANSI.

### Installation

The butterfly valves can be mounted into horizontal, vertical or inclined pipeline so that the arrow stamped on the valve body corresponds with the direction of the tightness (arrow points from higher pressure to lower when the disc is closed), and the rotating axe of the disc is in a horizontal position. The bolt type at the pivot area is also very important. When there is a butterfly valve with electric actuator it is important to abide the actuator's manufacturer.

Fig. A

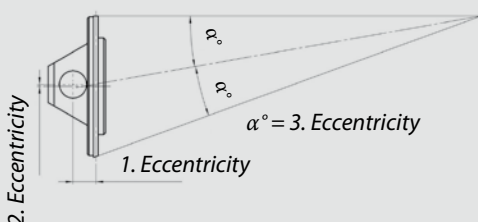

Fig. B

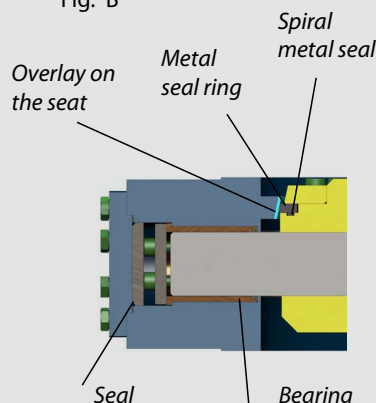
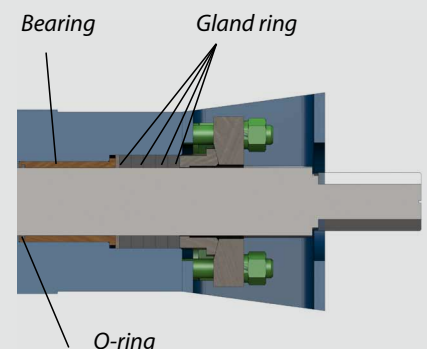

Fig. C







DN 80-1000 • PN 6-40 • T<sub>max</sub> 550 °C  
 Design: cast

Connection:  EN 1092-1 WAFERTYPE

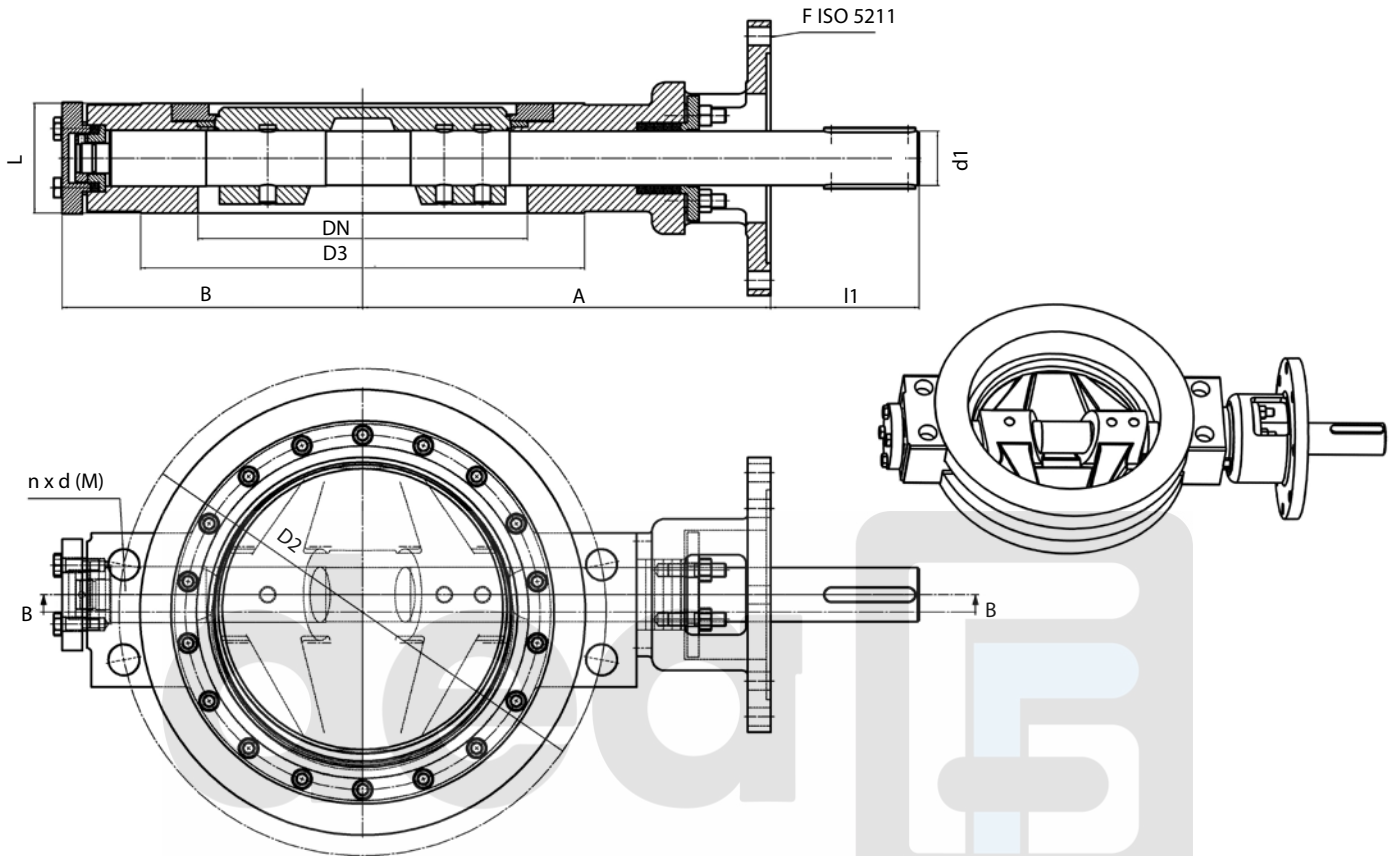

### PN 6

DN	A	B	L	D2	D3	d1	l1	F	M	kg
80	180	98	49	-	128	22	33	F10	-	7,5
100	195	112	56	-	148	22	33	F10	-	10,5
125	207	125	64	-	178	22	33	F10	-	19,5
150	264	155	70	-	202	24	36	F12	-	22
200	296	200	71	280	258	24	36	F12	M16	27
250	330	231	76	335	312	28	42	F12	M16	37
300	373	261	83	395	365	32	48	F14	M20	56
350	410	298	92	445	415	36	54	F16	M20	77
400	465	331	102	495	465	40	60	F16	M20	120
450	496	369	114	550	520	44	66	F16	M20	158
500	530	404	127	600	570	50	70	F25	M20	205
600	610	473	154	705	670	60	80	F25	M24	310
700	680	538	165	810	775	70	80	F25	M24	407
800	744	615	190	920	880	80	110	F30	M27	563
900	835	628	203	1020	980	90	110	F30	M27	900
1000	875	705	216	1120	1080	100	130	F30	M27	998



DN 80-1000 • PN 6-40 • Tmax 550 °C

Design: cast

Connection:  EN 1092-1 WAFERTYPE

PN 10

DN	A	B	L	D2	D3	d1	l1	F	M	kg
80	180	98	49	-	138	22	33	F10	-	13,5
100	195	112	56	-	158	22	33	F10	-	15,5
125	207	125	64	-	188	22	33	F10	-	22,5
150	264	155	70	-	212	24	36	F12	-	25
200	296	200	71	295	268	24	36	F12	M20	28
250	330	231	76	350	320	28	42	F12	M20	39
300	373	261	83	400	370	32	48	F14	M20	58
350	410	298	92	460	430	36	54	F16	M20	80
400	465	331	102	515	482	40	60	F16	M24	123
450	496	369	114	565	532	44	66	F16	M24	161
500	530	404	127	620	585	50	70	F25	M24	201
600	610	473	154	725	685	60	80	F25	M27	313
700	680	538	165	840	800	70	80	F25	M27	412
800	744	615	190	950	905	80	110	F30	M30	567
900	835	700	203	1050	1005	90	110	F30	M30	950
1000	875	705	216	1160	1110	100	130	F30	M33	1002

PN 16

DN	A	B	L	D2	D3	d1	l1	F	M	kg
80	180	98	49	-	138	22	33	F10	-	13,5
100	195	112	56	-	158	22	33	F10	-	15,5
125	207	125	64	-	188	22	33	F10	-	22,5
150	264	155	70	-	212	24	36	F12	-	25
200	296	200	71	295	268	32	48	F12	M20	30
250	330	231	76	355	320	36	54	F14	M24	41
300	373	261	83	410	378	40	60	F16	M24	60
350	410	298	92	470	438	44	66	F16	M24	83
400	465	331	102	525	490	55	70	F25	M27	128
450	496	369	114	585	550	60	80	F25	M27	177
500	530	404	127	650	610	70	80	F25	M30	239
600	610	473	154	770	725	80	110	F30	M33	374
700	680	538	165	840	795	90	110	F30	M33	432
800	744	615	190	950	900	100	130	F30	M36	587
900	835	700	203	1050	1000	120	170	F40	M36	980
1000	897	730	216	1170	1115	120	180	F40	M39	1022

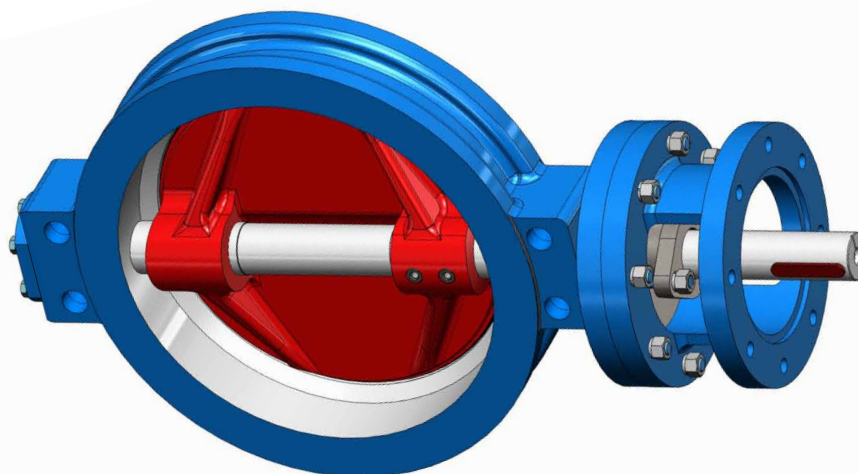



DN 80-1000 • PN 6-40 • Tmax 550 °C  
Design: cast

Connection: EN 1092-1 WAFER TYPE

## PN 25

DN	A	B	L	D2	D3	d1	I1	F	M	kg
80	180	98	49	-	138	22	33	F10	-	15,5
100	195	112	56	-	162	22	33	F10	-	17,5
125	207	125	64	-	188	22	33	F10	-	26,5
150	264	155	70	-	218	24	36	F12	-	27
200	296	200	71	310	278	32	48	F12	M24	32
250	330	231	76	370	335	36	54	F14	M27	45
300	373	261	83	430	395	40	60	F16	M27	69
350	410	298	92	490	450	44	66	F16	M30	94
400	465	331	102	550	505	55	70	F25	M33	145
450	496	369	114	600	548	60	80	F25	M33	207
500	530	404	127	660	615	70	80	F25	M33	270
600	610	473	154	770	720	80	110	F30	M36	405
700	680	538	165	875	820	90	110	F30	M39	483
800	744	615	190	990	930	100	130	F30	M45	656
900	835	700	203	1090	1030	120	170	F40	M45	1020

## PN 40

DN	A	B	L	D2	D3	d1	I1	F	M	kg
80	180	98	49	-	138	22	33	F10	-	20,5
100	195	112	56	-	162	22	33	F10	-	30,5
125	256	125	70	-	188	28	46	F12	-	35
150	270	165	76	-	218	32	48	F12	-	40
200	310	219	89	320	285	36	54	F14	M27	60
250	362	261	114	385	345	40	57	F16	M30	80
300	424	289	114	450	410	44	66	F25	M30	110
350	460	320	127	510	465	55	70	F25	M33	150
400	502	357	140	585	535	60	80	F25	M36	200
450	540	385	152	610	560	70	90	F30	M36	230
500	578	431	152	670	615	80	110	F30	M39	334
600	660	492	178	795	735	90	110	F30	M45	585

